

 **KNIKMOPS**
ENGINEERED TO PERFORM

KM 250

TECHNISCHE GEGEVENS



KM 250

KM250

KM250TE

mm	Wielbasis	A	1875	1995
mm	Totale lengte zonder bak	B	3180	3440
mm	Totale lengte met bak	C	3980	4270
mm	Totale breedte	D	1180/1520	1180/1520
mm	Breedte bak	E	1500/1700	1500/1700
°	Maximale draaihoek	F	50	50
mm	Draaicirkel buitenkant	G	2800	2950
mm	Hoogte Rolbeugel /Hoogte ROPS-FOPS	H	2220/2430	2220/2430
mm	Zithoogte	I	1425	1425
mm	Bodemvrijheid	J	360	360
°	Inkiephoek vanaf grondvlak	K	30	30
mm	Hoogte giekcharnier	L	1410	1455
mm	Overlaadhoogte	M	2480	2625/3380
mm	Max. hoogte scharnier aanpik	N	2650	2775/3550
L	Inhoud brandstoftank		60	60
	Type dieselmotor (Yanmar)		4TNV88C	4TNV88C
kw/pk	Motorvermogen		35.5/48	35.5/48
	Aantal cilinders		4	4
	Aandrijfhydrauliek		plunjerpomp	plunjerpomp
	Wiel aandrijving		plunjermotor	plunjermotor
L/min	Debiet werkhydrauliek		63	63
bar	Werkdruk hydrauliek		180	180
kg	Rijklaar gewicht zonder hulpstuk		2380	2750
kg	Hefkracht		1800	1700
kg	Uitbreekkracht		1440	1415
km/h	Rijsnelheid		20	20

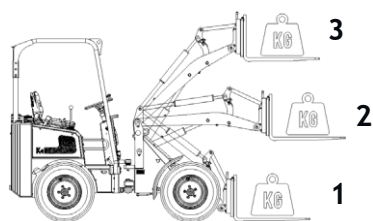
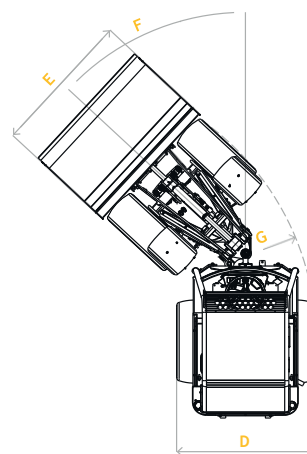
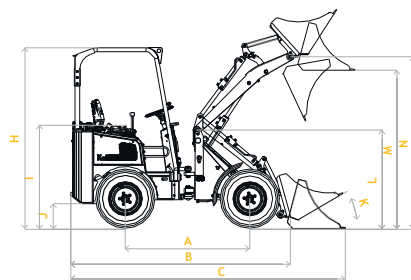

	1	2	3
KM 250 niet geknikt	2400	1630	980
KM 250 TE niet geknikt Telescooparm ingeschoven	1600	1350	950
KM 250 TE niet geknikt Telescooparm uitgeschoven	1050	880	700

Gegevens onder voorbehoud Gebroeders Geens (01-2021)

