

Tracked carriers

HEAVY LINE

BT350D



B-TRACK

General Features

- Tracked dumper with hydrostatic transmission with axial piston pump and two hydraulic motors with double speed.
- Controls are pilot assisted assembled on the 180° rotating driver's seat.
- STAGE V turbo diesel common rail engine with DPF. - Auto Two Shift.
- Canopy standard. - Loading vessel with 180° swivel tipping operated by one slew motor, controlled by joy-sticks.
- Versatile track body to be used in a wide range of application (transport, crane and pile drivers mainly), particularly suited to safely drive on soft or muddy ground.
- Available two different track sizes to reduce the ground pressure and overcome all the most slippery and highest gradient slopes.
- Closed cab - 450 mm wide tracks (compulsory with closed cab)
- Hydraulic P.T.O. 50 l/min at 175 bar
- High Flow 80 l/min at 175 bar - Towing hook.



B-TRACK

Technical Data

MOTORE MOTEUR		
Turbo Diesel engine STAGE V with electronic DPF Turbo Dieselmotor mit elektronischem DPF	type typ	KUBOTA V2403M-CR Turbo - STAGE V
Max. power (2700 rpm) Max. Leistung (2600 U/min)	kW/HP PS	48,6 / 65,7
Cylinders Zylinder	n°	4
Displacement Hubraum	cm ³	2434
Max. torque at 1600 rpm Drehmoment max. 1600 U/min	daNm	19.8
Cooling Kühlung	type typ	water wasser
Operational weight with canopy (320 mm/ 450 mm tracks) Betriebsgewicht mit Schutzdach (320/ 450 mm Ketten)	kg	3540/3750
Operational weight with closed cab (450 mm tracks) Betriebsgewicht mit Kabine (450 mm Ketten)	kg	3960
Operational loading Nutzlast	kg	3500
Swivelling Skip capacity (heaped SAE norms/ struck/ liquids) CLadekapazität (gehäuft SAE Norm/ flach/ Flüssigkeit)	m ³	1.88/1.60/1.07
Transmission Getriebe	tipo typ	hydrostatic hydrostatisch
Axial piston pump with variable cubic capacity Getriebekolbenpumpen mit variablem Hubraum	n°	2
Total capacity Förderleistung total	l/min	77x2
Utilities gear pump Zahnradpumpe (Arbeitshydraulik)	n°	1
Capacity Förderleistung	l/min	50
Max. working pressure for translation Betriebsdruck max. für Fahrhydraulik	bar	330
Max. working pressure for utilities Betriebsdruck max. für Arbeitshydraulik	bar	175
Speed with manual shift (I speed / II speed) Erste / Zweite Geschwindigkeit	km/h	0-5/ 0-12
Speed with automatic shift (Auto Two Shift) Geschwindigkeit mit automatischer Schaltung (Auto Two Shift)	km/h	0-12
Steering system through independent tracks Lenksystem mit unabhängigen Raupen	type typ	hydrostatic hydrostatisch
Rubber tracks tensioning Spannung der Gummiraupen	type typ	with grease schmierfett
Specific ground pressure with canopy: with 320/450 mm wide tracks empty- loaded Bodendruck: im Leerzustand / beladen mit Raupenbreite 320/450mm	kg/cm ²	0.313 - 0.6238 /0.225 - 0.443
Max. gradient capability full loaded Max.befahrbare Steigung bei Vollast	max. %	70
REFUELLING FÜLLMENGEN		
Fuel tank capacity Kraftstofftank	l	70
Fuel tank capacity Hydrauliköltank	l	55

Data, features and pictures are not binding and may be altered without any prior notice. Dimensions in mm

B-TRACK

Dimensions

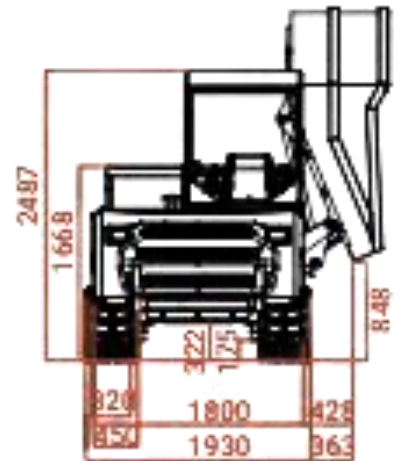
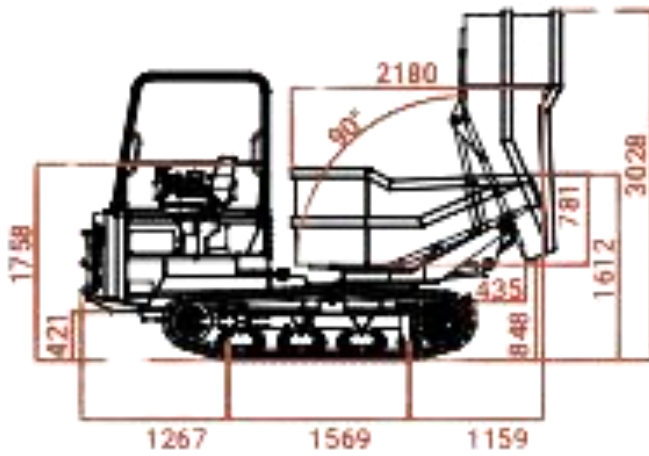
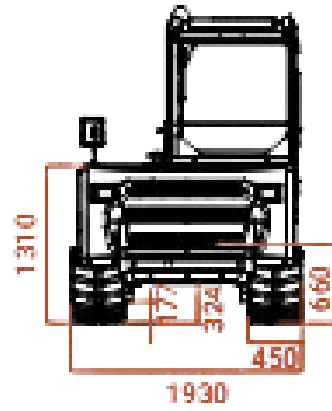
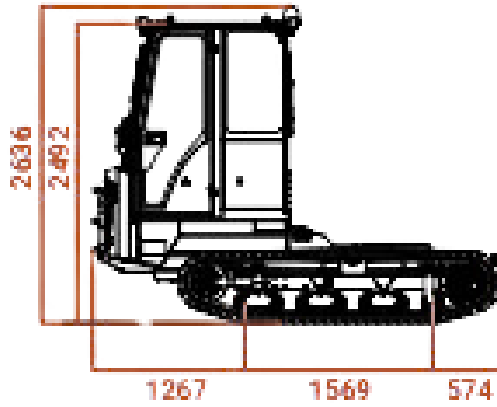

B-TRACK