

Tracked carriers

ZERO EMISSION LINE

BT50e - BT120e



B-TRACK

General Features

BT50e

PAYLOAD 500 KG

- Tracked undercarriage with mixed hydraulic/battery chain drive.
- Emergency button to ensure maximum operator safety.
- BMS (Battery Management System) to control the status of the battery.
- The complete charge of the battery (Lithium-Iron-Phosphate type) can ensure a day shift work capacity (5-6 hours).
- Also available in Hi-Tip skip version.

BT120e

PAYLOAD 120 KG

- Tracked undercarriage with fully battery chain drive.
- Two inverters, two electric motors (heavy duty designed to work also in the tougher conditions) and two planetary gears.
- Emergency button and negative brakes to ensure maximum operator safety.
- Tilting rollers and patented layout of track to ensure a wide footprint, high stability and excellent driving comfort in all conditions.
- Hydraulic circuit exclusively for the skip lifting and shovel with electric motor pump controlled by dedicated inverters.
- BMS (Battery Management System) to control the status of the battery.
- CAN-BUS control unit for diagnostics and control of all movements of the machine. Possibility of remote access to the machine data.
- The complete charge of the battery (Lithium-Iron-Phosphate type) can ensure a day shift work capacity (8 hours).
- Available remote-control unit as option.
- Also available with Hi-Tip skip (and self-loading shovel) and 180° swivel dumping skip.

B-TRACK

Technical Data

TECHNICAL DATA

TECHNISCHE DATEN

		BT50e	BT120e
Operational weight with shovel (without operator) Eigengewicht mit Ladeschaufel	kg	540	900
Payload Nutzlast	kg	500	1200
Skip capacity: heaped (SAE norms) Schüttmulden Volumen: gehäuft (SAE Norm)	m ³	0.304	0.440
Skip capacity: struck by sand/struck by liquids Schüttmulden Volumen: gestrichen Sand/gestrichen Flüssigkeit	m ³	0.265 / 0.180	0.340 / 0.210
Loading shovel capacity Ladeschaufel Volumen	l	50	65
Three-phase asynchronous electric motor with electronic control Drei Phasen asynchron Elektromotoren elektronisch gesteuert		•	
Nominal power Nominale Leistung	kW	5.5	
Nominal power of the driving motor Nominale Leistung je Motor	kW		2 X 2
Maximum rotation speed Max. U/min	rpm U/min	2850	2850
Rated voltage Nenn-Spannung	V	48	80
Maximum current offset Stromstärke max	A	130	33
Direct transmission to the planetary gear and negative brake Direktantrieb am Getriebemotor und Negativbremse			•
Maximum speed Fahrgeschwindigkeit max	km/h	1.5 / 3.0	4
Maximum gradient at full load Steigfähigkeit max. voll beladen	%	30	43
Ground pressure: empty / loaded Bodendruck leer/beladen	kg/cm ²	0.18 / 0.34	0.20 / 0.40
Track width Breite der Raupenkette	mm	180	180
Track tensioning Raupenkettenspannung	type typ	screw + spring Feder und Schraube	screw + spring Feder und Schraube
N. 3 gear pumps with total flow Drei Zahnradschöpfen mit einer Gesamtliterleistung	l/min	25	
Pump for services Pumpen für Arbeitshydraulik	type typ		gear pump Zahnradschöpfen
Maximum pressure for the track driving Max. Druck für die Rotation der Raupenkettens	bar	190	
Maximum pressure for the skip and the shovel Max. Druck für Mulden und Schaufel	bar	150	
Maximum pressure for services Pression max d'exercice services	bar		160
Flow Durchfluss	l/min		5
Battery pack nominal power Nennleistung des Akkus	kW	6.9	11.5
Cells type: LiFePO4 (Lithium-Iron-Phosphate) Typ der Zellen LiFePO4 (Lithium-Eisenphosphat)	n°	28 (14X2)	48 (24X2)
Minimum autonomy fully loaded continuous travel Reichweite je Akkuladung bei maximaler Auslastung	h	2.5	4
Average battery life (charge-discharge cycles) Lebensdauer des Akkus (Ladezyklen)	n°	2000	2000
Recharging time with STD charger Mittlere Ladezeit des Akkus (Standardladegerät)	h	8/10	7.5
Cooling of the controllers Kühlung der Steuereinheit	type typ	type aluminum heat sink Aluminium Kühlkörper	aluminum+fan Aluminium + Gebläse

B-TRACK

Dimensions

BT50e

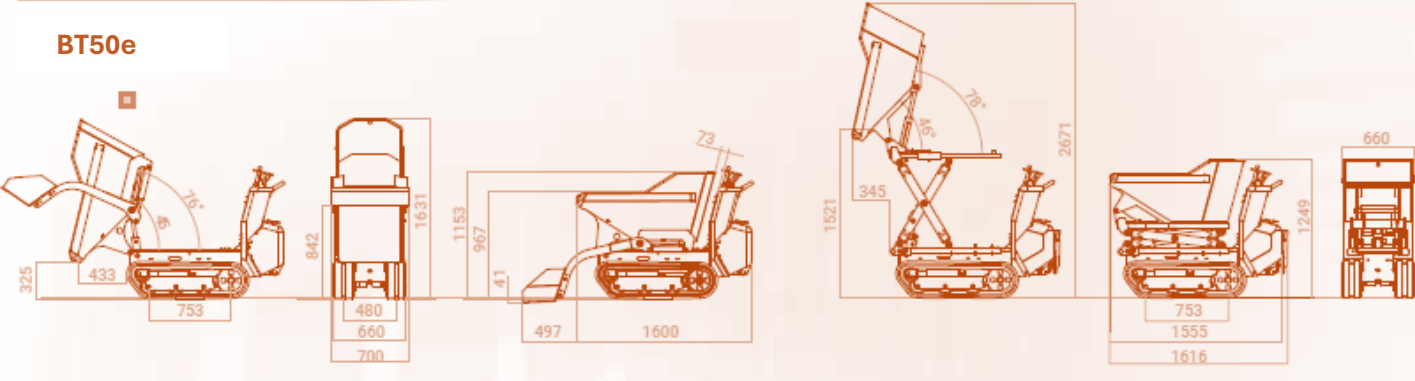

BT120e

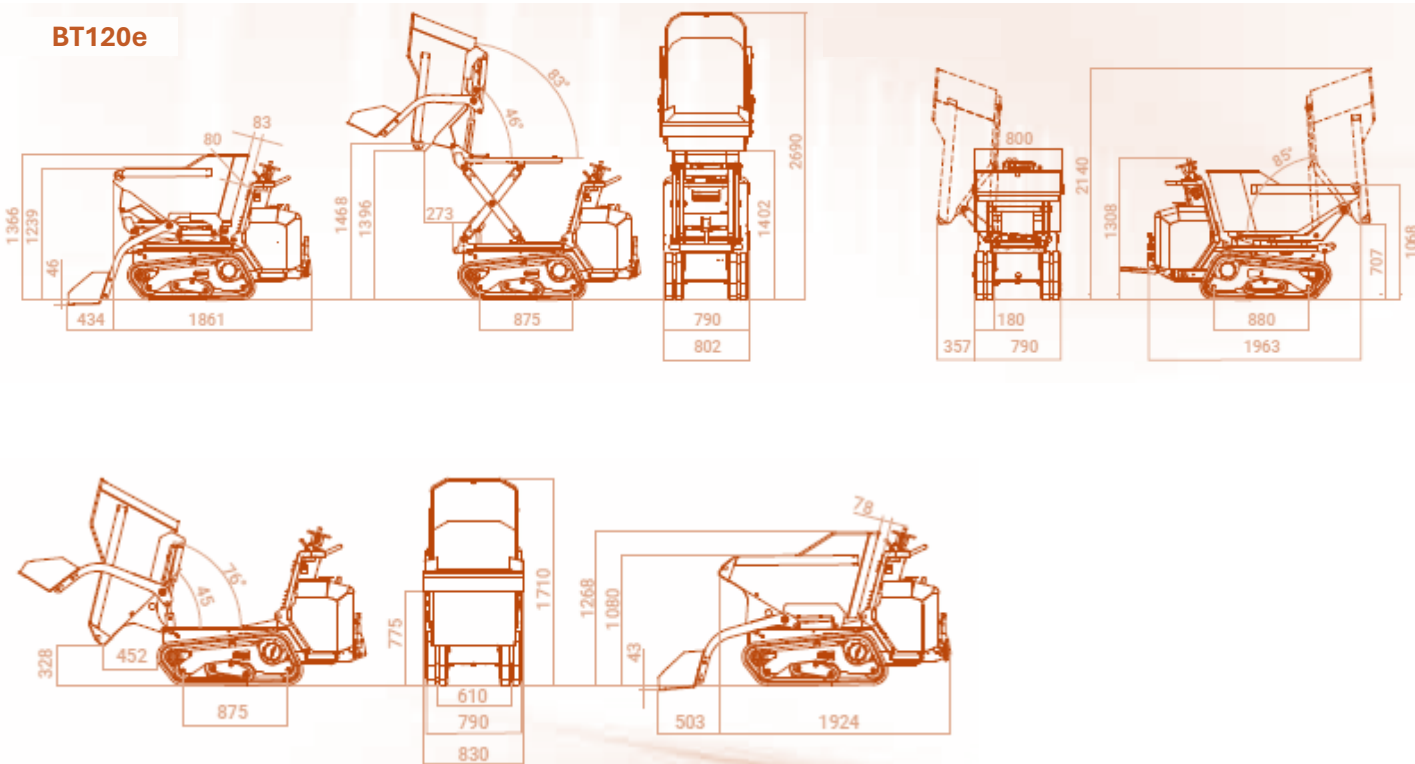

B-TRACK