

Tracked carriers

# HEAVY LINE

# BT550D



**B-TRACK**

# General Features

---

- Tracked dumper with hydrostatic transmission with axial piston pump and two hydraulic motors with double speed
- PERKINS Diesel engine TURBO COMMON RAIL 4 cylinders 85,9 kW (115 HP) STAGE V water cooled
- Servo controls with joysticks assembled on the 180° rotating driver's seat with driving sense reversion
- 600 mm wide tracks
- Closed cab with air conditioning
- Rear view camera
- Complete with 180° swivel dumping skip operated by one slew motor



**B-TRACK**

# Technical Data

<b>ENGINE MOTOR</b>		
Make and model Hersteller und Typ		Turbo Diesel engine STAGE V with DEF PERKINS 904J-E36TA Turbo Dieselmotor STAGE V mit DEF PERKINS 904J-E36TA
Operational weight with closed cab Betriebsgewicht mit Schutzdach	kg	7000
Operational loading Nutzlast	kg	5000
Swiveling Skip capacity (heaped SAE norms, struck, liquids) Ladefähigkeit (gehäuft SAE norm, flach, Flüssigkeit)	m <sup>3</sup>	2.87/2.43/1.43
Max. power (2400 rpm) Max. Leistung (2400 U/min)	kW/HP	85.9 /115.2
Displacement Hubraum	cm <sup>3</sup>	3600
Cylinders Zylinder	n°	4
Max. torque at 1500 rpm Drehmoment max. 1500 U/min	daNm	50.0
Cooling Kühlung	type typ	liquid wasser
Trasmissione Transmission	type typ	idrostatica hydrostatique
Axial piston pump with variable cubic capacity Getriebekolbenpumpen mit variablem Hubraum	n°	2
Total capacity Förderleistung total	l/min	125x2
Utilities gear pump Zahnradpumpe (Arbeitshydraulik)	n°	1
Capacity Förderleistung	l/min	65
Max. working pressure for translation Betriebsdruck max. für Fahrhydraulik	bar	450
Max. working pressure for utilities Betriebsdruck max. für Arbeitshydraulik	bar	200
Speed with automatic shift (Auto Two Shift) Geschwindigkeit mit automatischer Schaltung (Auto Two Shift)	km/h	0-11
Steering system through independent tracks Lenksystem mit unabhängigen Raupen	type typ	hydrostatic hydrostatisch
Larghezza cingoli in gomma Largeur des chenilles	mm	600
Rubber tracks tensioning Spannung der Gummiraupen	tipo type	with grease schmierfett
Specific ground pressure with canopy Bodendruck im Leerzustand/beladen	kg/cm <sup>2</sup>	0.28/0.44
Max. gradient capability full loaded Max. befahrbare Steigung bei Vollast	max%	57
<b>REFUELLING FÜLLMENGEN</b>		
Fuel tank capacity Kraftstofftank	l	125
Hydraulic oil tank capacity Hydrauliköltank	l	70

Data, features and pictures are not binding and may be altered without any prior notice. Dimensions in mm

# B-TRACK

# Dimensions

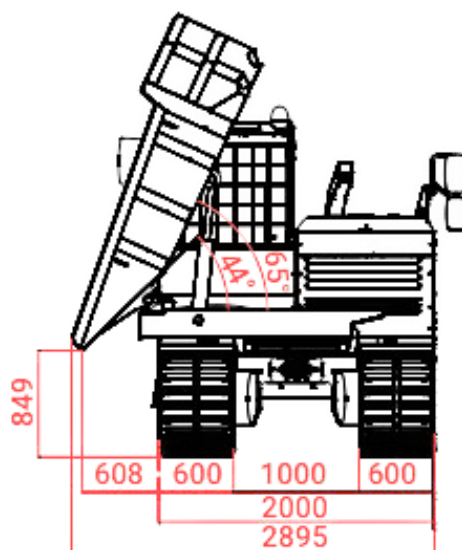
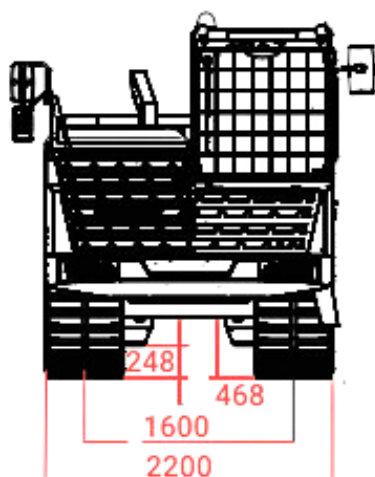
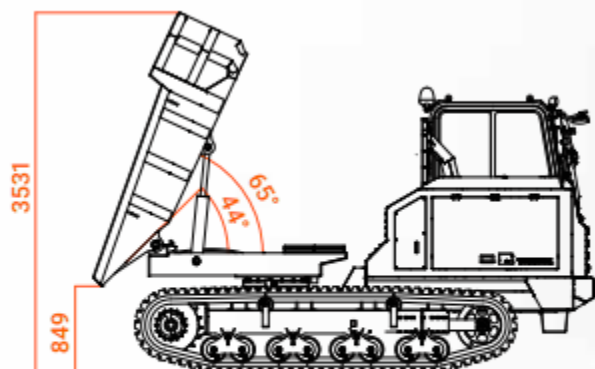
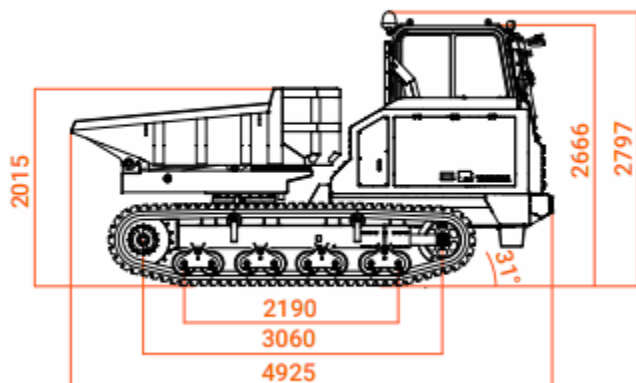

**B-TRACK**